

Morgana Systems Ltd
3909 Upland Way, Marietta
GA 30066 Georgia
USA

Tel: 866 463 5060
Fax: 770 565 6163

www.morganausa.com
morganausa@comcast.net



AutoCreaser Pro 50

High speed creaser with the NEW SmartScreen touch screen technology.



The AutoCreaser, made in the UK by Morgana, provides the complete solution to the problem of cracking that occurs when folding digitally printed output. It is equally effective in dealing with conventionally printed card, laminates or cross-grained stock.

Creasing versus Scoring.

Traditional rotary scoring machines use circular blades that are in constant motion as the stock passes through them. This creates a ploughing action that actually cuts through the top fibres of the paper or card in order to create a score. Inevitably this weakens the paper and encourages cracking. In contrast, the Morgana AutoCreaser Pro 50 employs a unique creasing rule and matrix as illustrated overleaf, that eliminates tearing and, therefore, cracking.

Key Product Features

- 7" SmartScreen touch screen
- 27.5" x 19.6" sheet size
- Intuitive and easy to use
- Fully automatic
- Up to 16 creases per sheet
- Takes stock up to 0.015" (approx 150lb cover)*
- Rule and matrix guaranteed for life
- 8500 sheets per hour
- Unlimited alpha numeric memory
- Adjustable crease depth & square
- Perforating as standard
- Crease without cracking

The new intuitive 7" SmartScreen controls all the main functions of the AutoCreaser Pro 50.

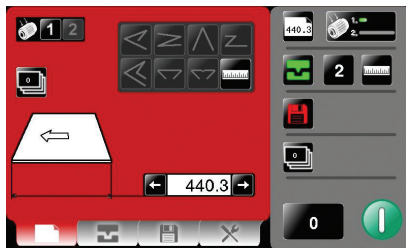

Using the screen is simplicity itself. Key in the sheet length (popular sizes are pre-set), touch the fold type for the finished product (letter, gate etc) and press the green button. The AutoCreaser Pro 50 will automatically calculate

where the creases need to be and set them accordingly.

Any minor changes to the crease position can be made by touching an arrow in the relevant direction.

The productivity of the AutoCreaser Pro 50 has been improved with a



massive 30% increase in speed with no loss of accuracy. Now running at 8,500 8.5" x 11" sheets per hour, and an astonishing 11,000 6.5" x 8.5" sph this is our most productive creaser to date.

The increased sheet size of 27.5" x 19.6" can be extended with an optional tray making sheet lengths of 35.4" possible.

The AutoCreaser Pro 50 has the new Morgana PosiFeed feeding system. The drum stops as the vacuum pulls the sheet down before the drum starts to feed. This significant change will enable the feeder to be piled higher and feed the most difficult of stocks.

All settings and adjustments are made using the new SmartScreen and as only symbols are used, operation couldn't be simpler. An alpha-numeric memory allows an unlimited number of jobs to be stored and named as you choose. This makes job recall much easier as you can use your own job name and numbers for storage.

An alpha-numeric memory allows an unlimited number of jobs to be stored and named as you choose. This makes job recall much easier as you can use your own job name and numbers for storage.

Any changes to the suction drum, feed method, crease position and engineering settings are all made through the SmartScreen which we have developed and designed to make the AutoCreaser Pro 50 the easiest machine to operate whilst offering levels of sophistication never before seen at this price point.

Perforation comes as standard on the AutoCreaser Pro range with a wide variety of wheels available to suit all applications.

AutoCreaser Pro 50

High speed creaser with the NEW SmartScreen touch screen technology.



technical specifications

Maximum sheet size	27.5" x 19.6" (35.4" x 19.6" with optional extension table)
Minimum sheet size	8.2" x 5.5"
Maximum paper thickness	0.015" (approx 150lb cover)* including laminated material
Minimum paper thickness	0.004" (approx 20lb bond)*
Maximum number of creases per sheet	16
Maximum number programmed applications	Unlimited alpha numeric
Minimum repeat crease distance	0.03" (depending on paper weight)
Minimum crease distance from lead edge	0.09"
Minimum crease distance from tail edge	1.37"
Speed per hour	8500 sph (8.5" x 11"), 11,000 sph (6.5" x 8.5")
Dimensions	L 59" x W 26.8" x H 48"
Weight	344lb
Power requirement	240v 50/60hz
Options	Narrow creasing blade, Narrow sheet guide

Note: the production speed varies according to material size and the number of creases on the sheet

Creasing rule and matrix. The AutoCreaser Pro 50 uses an identical mechanism to all other creasers in the range including the DigiFold Pro and DocuMaster Pro and is guaranteed for life. With thousands of these mechanisms installed throughout the world our creasing technology is unparalleled in both performance and longevity.

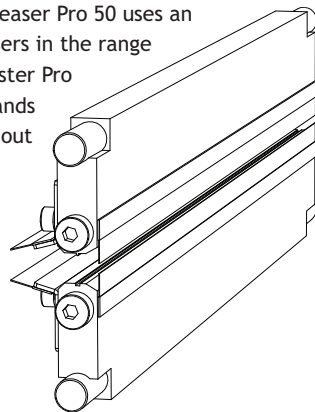

*Disclaimer

As part of our continued product improvement plan, specifications and information published here are subject to change without notice. All specifications are dependent on application, type of stock, temperature, RH and print engine used. Specifications quoted were measured on uncoated and unprinted stock. E & OE.